

SUPERIOR
CONTAINER SOLUTIONS

STATIONARY COMPACTORS



The New Industry Leader
For Waste Compaction Solutions.

STATIONARY COMPACTORS

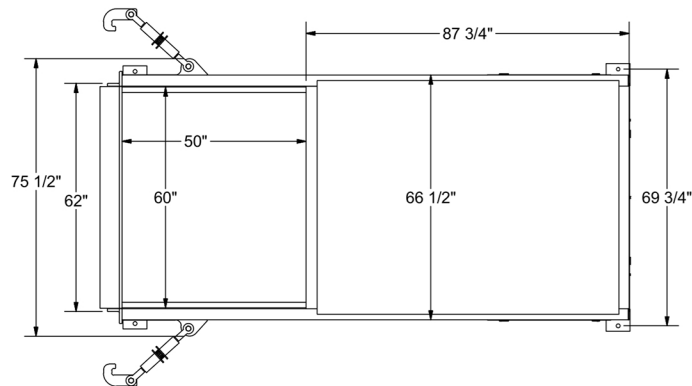
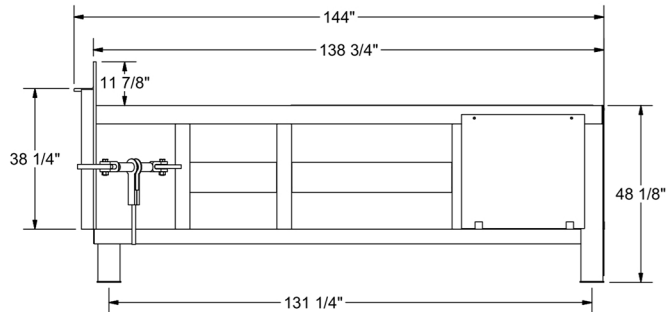

Physical Dimensions:	SCS200	SCS200HD	SCS300HD	SCS400HD
(A) OVERALL HEIGHT	48"	48"	48"	52"
(B) OVERALL WIDTH	74"	74"	74"	74"
(C) OVERALL LENGTH	120"	120"	180"	180"
(D) CHARGE BOX WIDTH	60"	60"	60"	60"
(E) CHARGE BOX LENGTH	44.5"	44.5"	70.5"	70.5"
(F) DISCHARGE HEIGHT	34"	34"	34"	34"

Capacity:				
CHARGE BOX CAPACITY (YDS)	1.90	1.90	2.90	2.90
CLEAR TOP OPENING (L X W)	44.5 X 58"	44.5 X 58"	67.5 X 58"	67.5 X 58"
Performance:				
CYCLE TIME (SEC)	69	60	68	60
NORMAL FORCE (LB)	52,307	60,789	52,307	60,789
MAXIMUM FORCE (LB)	60,789	67,858	60,789	67,858
RAM PENETRATION (IN)	14"	14"	14"	14"
Electrical:				
MOTOR (H.P)	10	10	20	20
CONTROL VOLTAGE (VAC)	110	110	110	110
STANDARD CONTROLS	START/ STOP /REVERSE/ LOW OIL			
POWER UNIT UL LISTED	YES	YES	YES	YES
Hydraulics:				
PUMP (GPM)	9.5	9.5	15.0	15.0
NORMAL PRESSURE (PSI)	1850	2150	1850	2150
MAXIMUM PRESSURE (PSI)	2150	2400	2150	2400
CYLINDER (IN)	6X2.5	6X4	6X4	6X4
WEIGHT (LB)	4550	4870		

Optional Features
Multi Cycle Time
Sonaizaire Odor Control System
Oil Heater
Low Oil Shutdown
AR 400 Floor
Overall Run Time
Low Oil Temp
Breaker Bar Teeth
Remote Control
Guide Rails
24 Volt Control
Steel Options
Open Hopper
Walk Up
Walk On
Chute Feed
Cart Tipper
Total Enclosure

Standard Color Choices



superiorcontainersolutions.com

602-313-8075